

Standard type

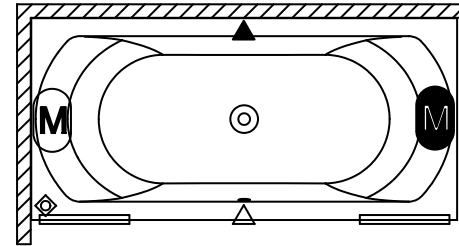

Left type

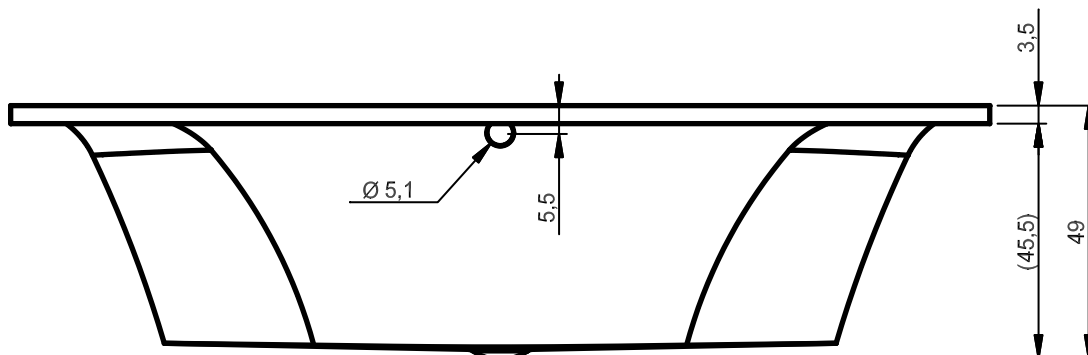
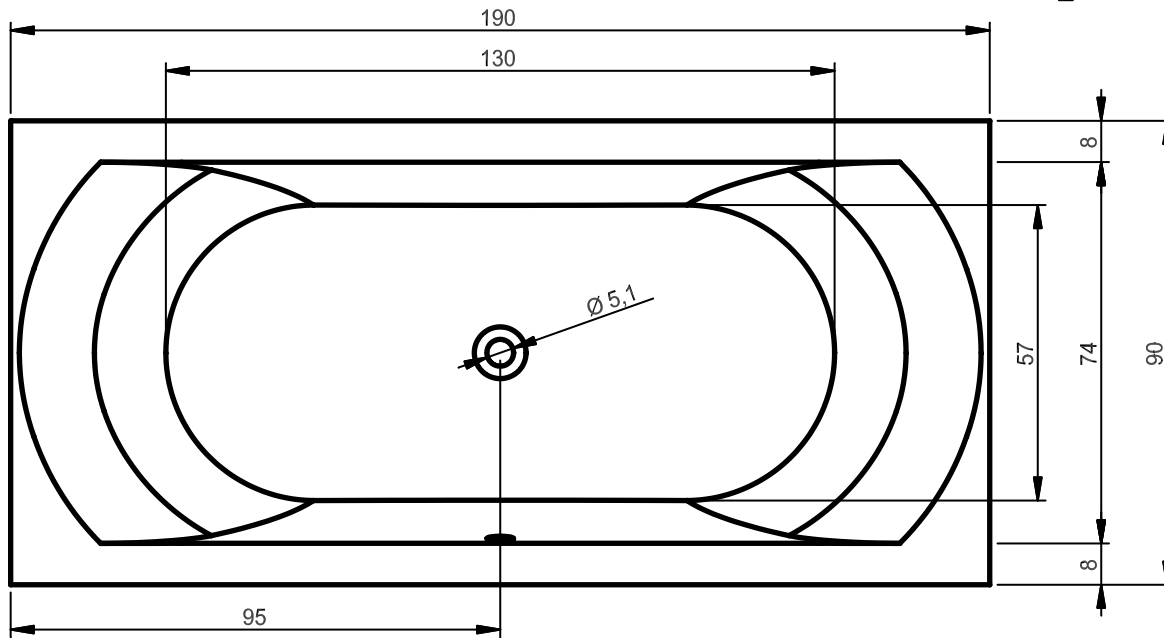
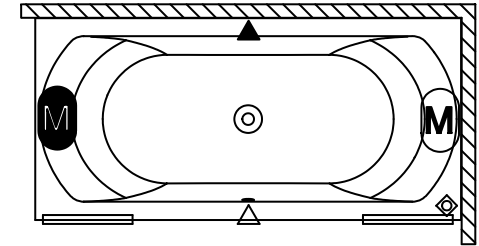

Motor aero in double system (Hydro/Aero)
Motor aero v kombinovaném systému (Hydro/Aero)



Motor of single system (Hydro or Aero) or hydro motor in double system (Hydro/Aero)
Motor jednoduchého systému (Hydro nebo Aero) nebo motor hydro v kombinovaném systému (Hydro/Aero)



Electronic control / Elektronické ovládání



LCD electronic control / LCD elektronické ovládání



Pneumatic control or cleanpool (combination of pneumatic control and cleanpool is not possible)
Mechanické ovládání nebo čištění (kombinace mechanického ovládání a čištění není možná)

Special attachment of Cleanpool – see drawing Z0101009
Speciální připojení Cleanpoolu – viz výkres Z0101009

— Inspection hatches / Servisní otvor

Treatment:			
Material: Acryl 3,2mm			
Rev./Change	n/Dev./	Date	Rev./Change
A			C
B			D
			E
			F
			G
			H
Scale: 1:15 Format: A4 Unit: mm Sheet: 1 of 1 Tolerance: NEN-ISO 2768-1 class v			
Name: Lima 190x90 Line drawing			<p>Third angle</p>
TILBURG HOLLAND Drawn: Michel vd Ven Date: 14-10-2004 Introduced by tech. change 28/2005 Article nr.:			
Project no.: 10.205 Draw.no.: BB480000			